

Saphenous Vein Harvesting Trainer

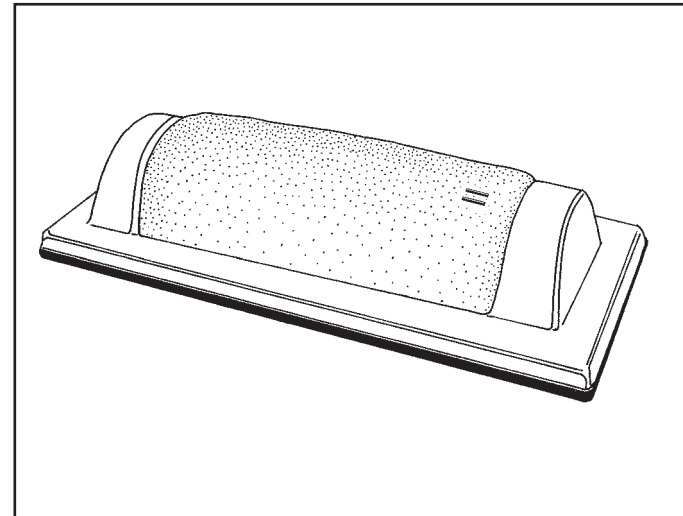

User Guide Contents

Information about the Trainer	2
List of components in the Trainer	2
Setting up the Trainer.....	3
Dismantling the Trainer	3-5
Replacing the veins	5-7
Re-assembling the Trainer.....	7-9
Care Information	10

Saphenous Vein Harvesting Trainer

- This Saphenous Vein Harvesting Trainer **80093** has been developed for balloon harvesting procedures and is a very important model for professional and demonstration purposes.
- There are gel-filled saphenous and perforating veins; held within a tunnel as if created by the use of a vein harvesting balloon. The space is cushioned by connective tissue, fat and skin.
- Entry ports are pre-formed; the veins are replaceable. All other parts are permanent or semi-permanent.

Replaceable Items:

- | | |
|--|-----------------------------|
| - Saphenous Vein | Re-order Code: 80092 |
| - Harvesting Trainer Skin | Re-order Code: 80096 |
| - Harvesting Trainer Connective Tissue | Re-order Code: 80095 |
| - Harvesting Trainer Suspension Tube | Re-order Code: 80094 |

Setting up the Trainer:

Position the trainer on the workbench and clamp into place **fig 1**.

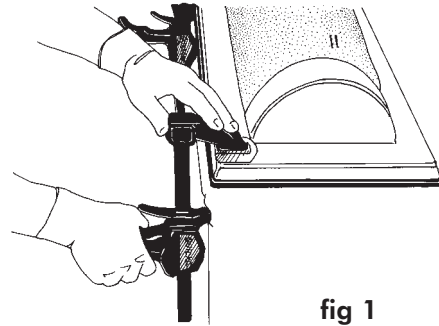

fig 1

3. To gain access to the vein suspension tube, release the skin by separating the velcro strips on the side and front of the trainer **figs 4 & 5**.

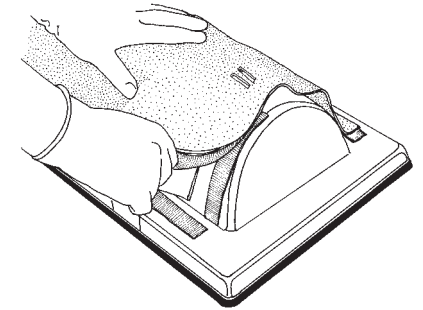

fig 4

Replacing the Veins:

Re-order Code: 80092 Saphenous Vein.

Dismantling the trainer:

1. Undo the black turnclips at either end of the model **fig 2**.

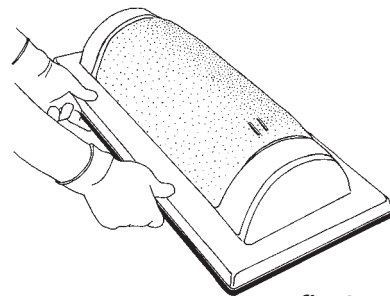

fig 2

2. Lift the top cover all the way back so that it is resting on the bench **fig 3**.

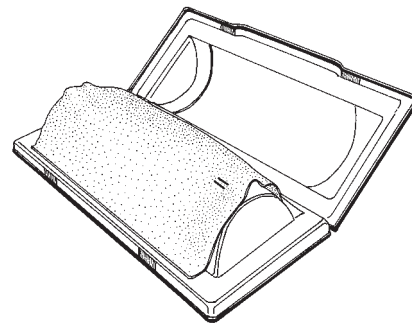

fig 3

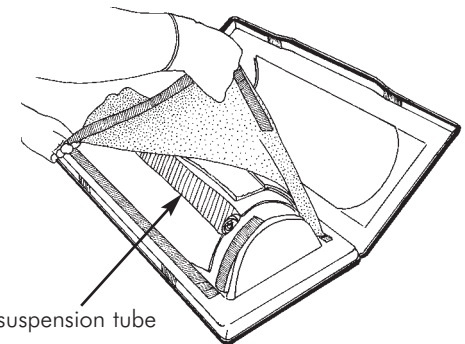

fig 5

4. Lift out the vein suspension tube. This is covered in yellow connective tissue **figs 6 & 7**.

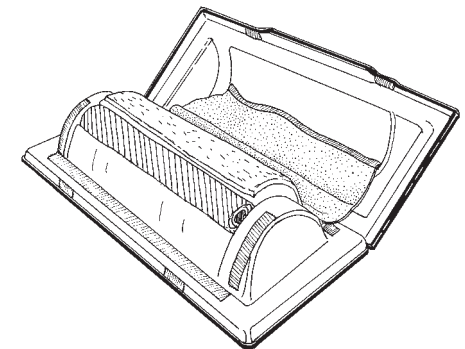

fig 6

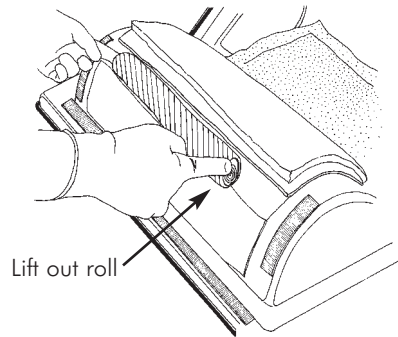

fig 7

5. Unroll the connective tissue and lift the suspension tube out and discard the remains of the old vein **fig 8**.

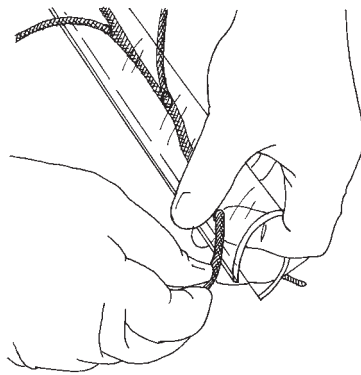

fig 8

Replacing the Veins:

1. Orientate the replacement vein with the tube as shown **fig 9**.

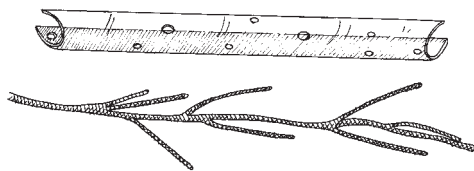

fig 9

2. Thread the 2 ends of the vein through the holes at either end of the tube and draw the vein along the slot to engage it **fig 10**.

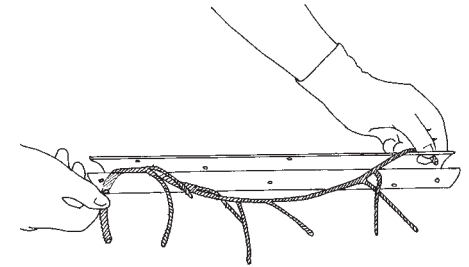

fig 10

3. Repeat this until each of the tributaries is poking out of its relevant hole **fig 11**.

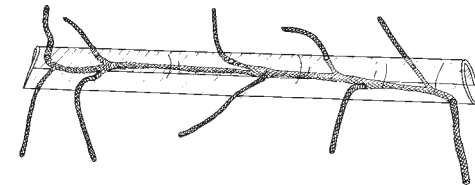

fig 11

4. Lay the connective tissue flat and place the tube on the top **fig 12**.

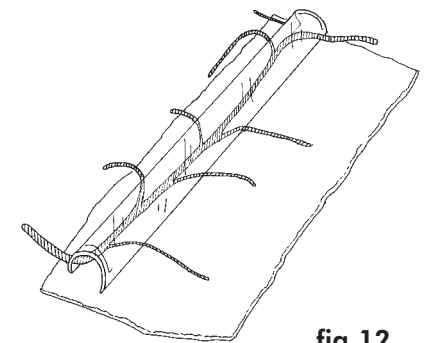

fig 12

5. Roll the connective tissue around the tube **fig 13.**

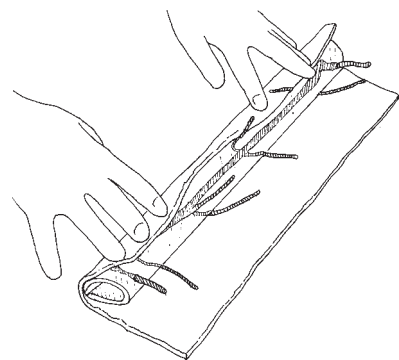

fig 13

6. In the final position ensure that the opening along the tube is pointing downwards **fig 14.**

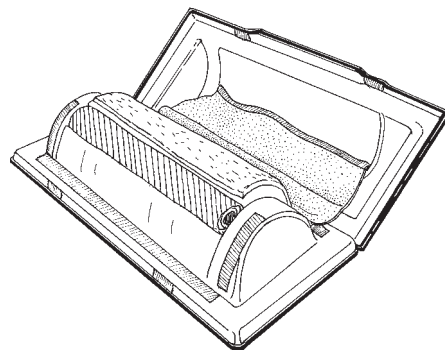

fig 14

Re-assembling the trainer:

1. Replace the skin by attaching the Velcro on the far side of the trainer. Ensure that the slit in the skin aligns with the groove on the end of the base **fig 16.**

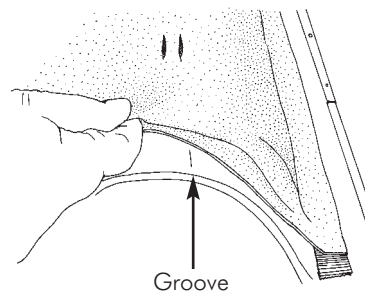

fig 15

2. Fix the Velcro along the nearside edge **fig 16.**

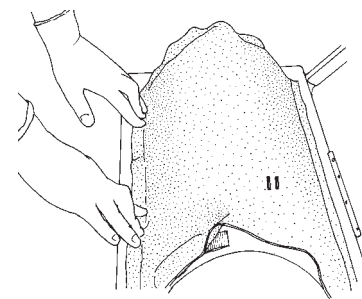

fig 16

3. To make the skin taut pull the side edge and attach to the Velcro **fig 17.**

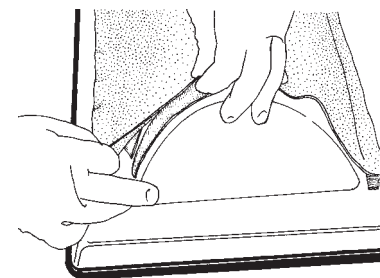

fig 17

4. Replace the upper frame and fix it in position with the black turnclips **fig 18.**

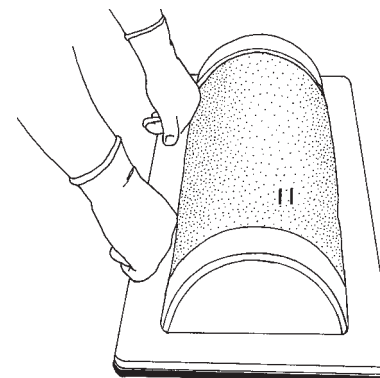

fig 18

5. The trainer is now ready to be used
fig 19.

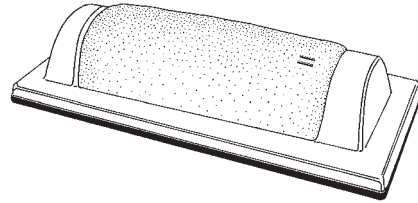

fig 19

Care of products made from Latex Foam Rubber:

1. Latex foam is a natural product; store away from strong light and in an airtight bag to reduce exposure to ozone. Ozone is generated by some electrical equipment including telephones and computers.
2. Wash your hands before touching the foam. (If the foam is handled after contact with certain metals such as copper, it becomes yellow and discoloured).
3. The foam may be washed effectively by hand or in a machine using any soap and rinsed afterwards. 'Vanish'™ soap is very effective.
4. Do not ingest the product and practice normal hygiene after handling the products.